

# MARVIN ROAD ANNEXATION SIGNAL IMPROVEMENTS

LACEY CONTRACT # PW 2023-27  
SECTION 14, T18N, R1W, W.M.

**LACEY CITY OFFICIALS**

**MAYOR:** Andy Ryder  
**DEPUTY MAYOR:** Malcolm Miller  
**CITY COUNCIL:** Lenny Greenstein  
Michael Steadman  
Carolyn Cox  
Robin Vazquez  
Nicholas Dunning  
**CITY MANAGER:** Rick Walk  
**CITY ATTORNEY:** David S. Schneider  
**CITY ENGINEER:** Aubrey Collier, P.E., S.E.  
**DIRECTOR OF PUBLIC WORKS:** Scott Egger, P.E.

**SHEET INDEX**

SHEET NO.	PAGE NO.	DESCRIPTION
1	CS	COVER SHEET
2	GN	GENERAL NOTES, LEGENDS & ABBREVIATIONS
3	TS1	3RD AVENUE SIGNAL PLAN
4	TS2	3RD AVENUE WIRING DIAGRAM
5	TS3	STEILACOOM ROAD SIGNAL PLAN
6	TS4	STEILACOOM ROAD WIRING DIAGRAM
7	TS5	TRAFFIC SIGNAL DETAILS

*Scott Egger*  
 \_\_\_\_\_  
 PUBLIC WORKS DIRECTOR                      DATE

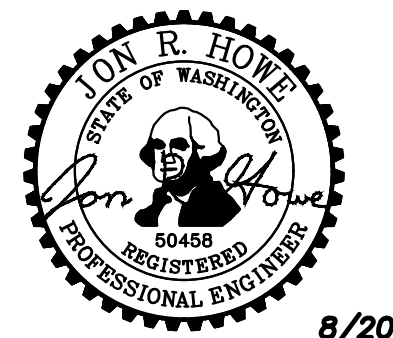
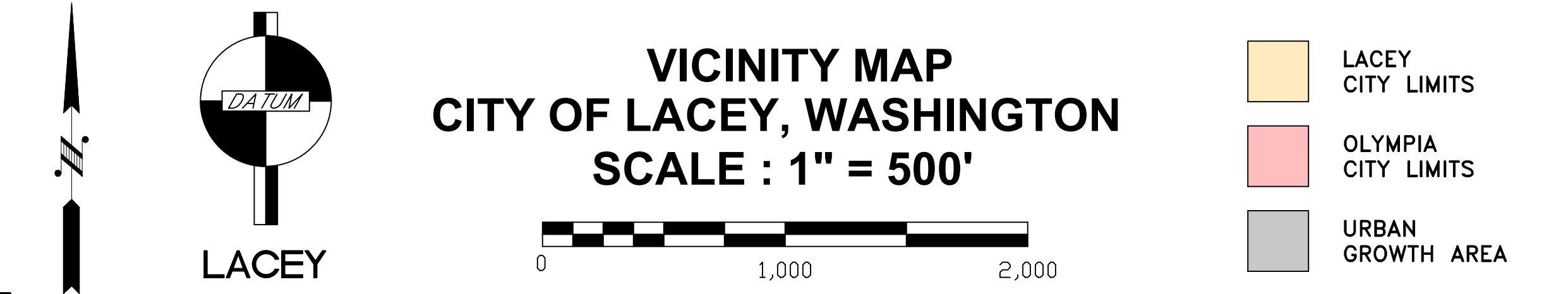
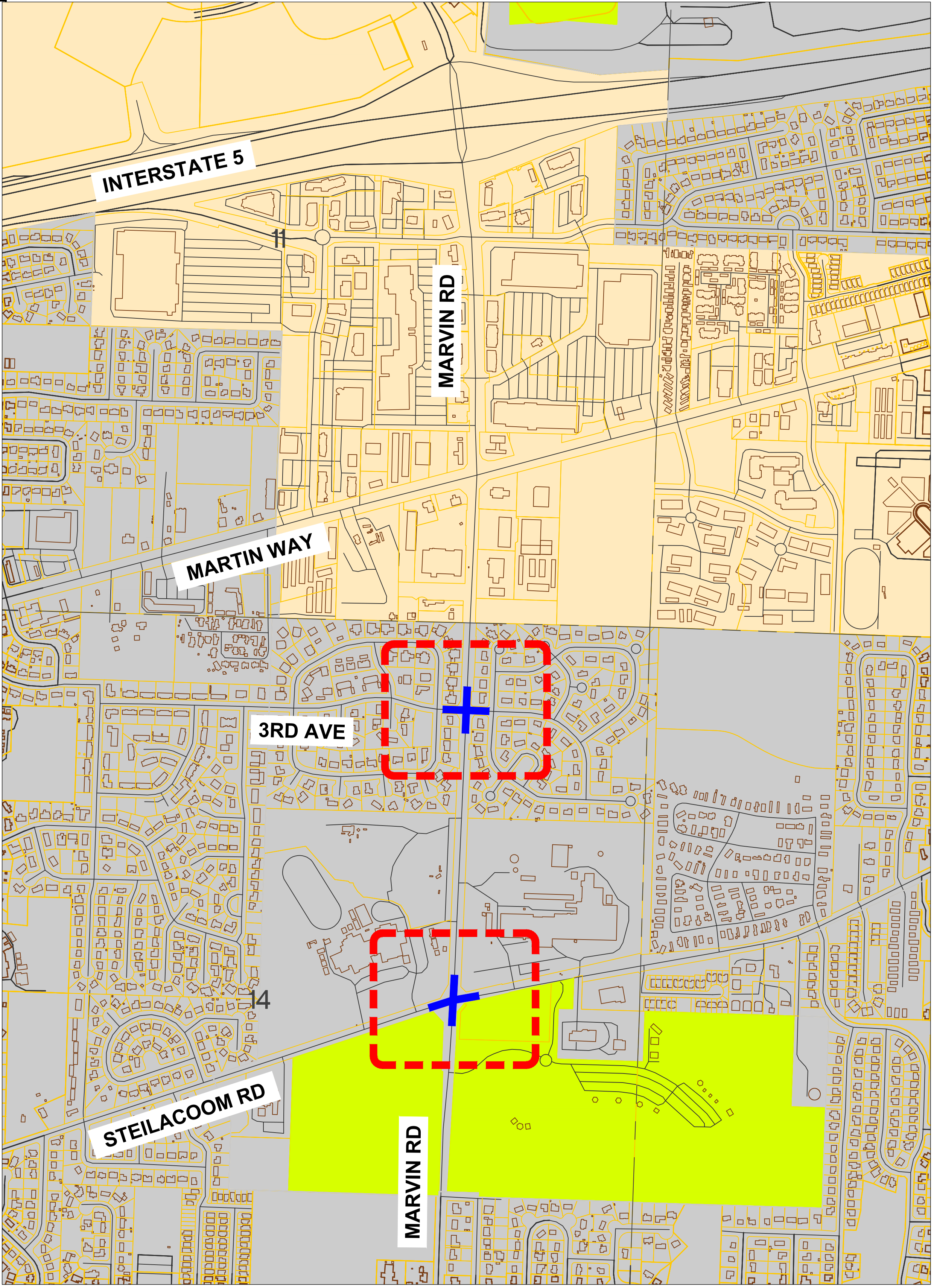

8/20/25

Lacey Dwg. Number :  
D-25-21

K:\Projects\2023\PW 2023-27 Marvin Road Annexation Signal Improvements\Design\0.4 Design Information\0.4.3 AutoCAD Files\Sheets\Cover Sheet.dwg, 08-28-25, 1:14pm, Howe, 1

K:\Projects\2023\PM 2023-27 Marvin Road Annexation Signal Improvements\Design\0.4.3 AutoCAD Files\Sheets\General Notes.dwg, 08-21-25, 12:22pm, JHowe, 1

**BLOCK LEGEND**

NEW	EXISTING	NEW	EXISTING

**LINE TYPE LEGEND**

	CONSTRUCTION BASELINE
	EASEMENT
	ROAD CENTERLINE
	BARB WIRE FENCE
	CHAIN LINK FENCE
	CONCRETE FENCE
	ROCK FENCE
	WIRE FENCE
	WOOD FENCE
	GRAVEL
	TOE OF SLOPE
	TOP OF SLOPE
	DITCH
	STORM (PAINTED)
	SEWER (PAINTED)
	RIGHT OF WAY
	OVERHEAD CABLE
	UNDERGROUND CABLE (PAINTED)
	GAS (PAINTED)
	OVERHEAD PHONE
	OVERHEAD FIBER OPTIC
	UNDERGROUND PHONE (PAINTED)
	UNDERGROUND FIBER OPTIC (PAINTED)
	OVERHEAD ELECTRIC
	UNDERGROUND ELECTRIC (PAINTED)
	WATER (PAINTED)
	RECLAIMED WATER (PAINTED)
	ABANDON EXISTING UTILITY (SEE PLAN)
	BREAK LINE OR PAVEMENT SEAM
	SILT FENCE
	HIGH VISIBILITY FENCE

**ABBREVIATIONS**

	DEFLECTION ANGLE
EP	EDGE OF PAVEMENT
RT	RIGHT
LT	LEFT
I.E.	INVERT ELEVATION
P.C.	POINT OF CURVATURE
P.I.	POINT OF INTERSECTION
P.T.	POINT OF TANGENCY
R.	RADIUS
R.P.	RADIUS POINT
R/W	RIGHT-OF-WAY
ROW	RIGHT-OF-WAY
EX.	EXISTING
EXIST.	EXISTING
STA	STATION
S/W	SIDEWALK
C.S.B.C.	CRUSHED SURFACING BASE COURSE
C.S.T.C.	CRUSHED SURFACING TOP COURSE
CL, C	CENTERLINE
CB	CATCH BASIN
N/A	NOT APPLICABLE
A/C	ASPHALT CONCRETE
ACP	ASPHALT CONCRETE PAVEMENT
D.I.	DUCTILE IRON
SD	STORM DRAIN
SS	SANITARY SEWER
DIA, Ø	DIAMETER
A.P.	ANGLE POINT
V.P.I.	VERTICAL POINT OF INTERSECTION
V.P.C.	VERTICAL POINT OF CURVATURE
V.P.T.	VERTICAL POINT OF TANGENCY
EL.	ELEVATION
S.Y.	SQUARE YARD
C.Y.	CUBIC YARD
TYP.	TYPICAL
LUM.	LUMINAIRE
L.F.	LINEAR FEET
RD.	ROAD
DR.	DRIVE
PKWY.	PARKWAY
CONST.	CONSTRUCTION
FT.	FOOT
D/W	DRIVEWAY
APPROX.	APPROXIMATELY
U.O.N.	UNLESS OTHERWISE NOTED

**CONSTRUCTION NOTES:**

- CALL 48 HOURS BEFORE YOU DIG 1-800-424-5555.
- CONTRACTOR SHALL NOT REMOVE ANY TREES UNLESS INDICATED ON PLANS OR DIRECTED BY ENGINEER.
- CONTRACTOR SHALL MATCH HMA TO EXISTING PAVEMENT AND DRIVEWAYS AS DIRECTED BY THE ENGINEER.
- THE CONTRACTOR SHALL VERIFY QUANTITIES OF VALVE BOX AND MANHOLE COVERS TO BE RAISED OR ADJUSTED PRIOR TO PAVING OPERATIONS.
- THE CONTRACTOR SHALL VERIFY VALVE BOX AND MANHOLE COVER DIMENSIONS AS WELL AS REQUIRED ADJUSTMENT HEIGHTS OF THE PAVING RISERS TO MATCH FINAL OVERLAY GRADES.
- THE CONTRACTOR SHALL PROTECT ALL EXISTING SURVEY MONUMENTS AND PROPERTY CORNERS. THE CONTRACTOR SHALL BE RESPONSIBLE FOR ALL COSTS ASSOCIATED WITH RESTORING MONUMENTS OR PROPERTY CORNERS OUTSIDE OF THE CONSTRUCTION LIMITS.
- THE CONTRACTOR SHALL PLACE STEEL PLATES OVER EXPOSED TRENCH AS THE CONTROLLED DENSITY FILL CURES UNTIL THE TIME PAVEMENT REPAIR IS COMPLETED. ALL LANES OF TRAFFIC SHALL REMAIN OPEN DURING NON-WORKING HOURS. SEE TRENCH RESTORATION FOR PAVED AREAS DETAIL.
- THE CONTRACTOR SHALL POTHOLE ALL UTILITY CROSSING CONFLICTS. THE CONTRACTOR SHALL INFORM THE ENGINEER OF ALL CONFLICTS WITH THE PROPOSED PIPE

**METHOD OF SURVEY**

SURVEY IS APPROXIMATE. SURVEY WAS DEVELOPED BASED UPON AERIAL IMAGERY AVAILABLE AT TIME OF DESIGN. SURVEY WAS DRAWN BY THE DESIGN ENGINEER AND IS SUBJECT TO ERROR.

**SOURCE OF UTILITY MARKINGS**

UNDERGROUND UTILITIES ARE NOT SHOWN IN THE PLAN SET.

ALL UNDERGROUND TRAFFIC SIGNAL LOCATIONS IN THE PLAN SET ARE APPROXIMATE. AS-BUILT DRAWINGS WERE UTILIZED AS REFERENCE TO SHOW TRAFFIC SIGNAL LOCATIONS. THESE LOCATIONS WERE DRAWN BY THE DESIGN ENGINEER AND ARE SUBJECT TO ERROR.

**SOURCE OF EXISTING SIGNAL PLANS**

EXISTING WSDOT SR 510 (SR 5 TO PACIFIC AVE) PROJECT PLANS DATED 12/26/01 WERE UTILIZED AS REFERENCE TO SHOW EXISTING TRAFFIC SIGNALS INCLUDING WIRING DIAGRAMS.

TRAFFIC SIGNALS INCLUDING WIRING DIAGRAMS WERE DRAWN BY THE DESIGN ENGINEER AND ARE SUBJECT TO ERROR.

**CITY OF LACEY, WASHINGTON**  
 DEPARTMENT OF PUBLIC WORKS  
 420 COLLEGE STREET SE  
 LACEY, WA 98503-1238 (360) 491-5600



DESIGNED: JH  
 DRAFTED: JH  
 CHECKED: MAH  
 HORZ. SCALE: N/A  
 VERT. SCALE: N/A  
 FILE: GENERAL NOTES.DWG

**MARVIN ROAD ANNEXATION  
 SIGNAL IMPROVEMENTS  
 GENERAL NOTES**

REVISION BLOCK		
NO.	DATE	DESCRIPTION

PAGE NO.	SHEET NO.
GN	2
DWG NO.	OF
D-25-21	7

**CONSTRUCTION NOTES:**

- 1. SIGNAL STANDARD NO. 1  
INSTALL TWO CITY SUPPLIED AUDIBLE PEDESTRIAN PUSHBUTTON STATIONS WITH R10-3B INDICATION ON SIGNAL POLE. INSTALL CITY SUPPLIED INTERNALLY ILLUMINATED STREET NAME SIGN EQUIPMENT TO MAST ARM. REMOVE EXISTING STREET NAME SIGN. INSTALL CONTRACTOR SUPPLIED VEHICLE DETECTION CAMERA EQUIPMENT TO MAST ARM. LOCATION SHALL BE FIELD LOCATED BY THE ENGINEER PRIOR TO INSTALLATION. TERMINATE WIRING PER SHEET NO. TS-2.
- 2. SIGNAL STANDARD NO. 2  
INSTALL TWO CITY SUPPLIED AUDIBLE PEDESTRIAN PUSHBUTTON STATIONS WITH R10-3B INDICATION ON SIGNAL POLE. INSTALL CITY SUPPLIED INTERNALLY ILLUMINATED STREET NAME SIGN EQUIPMENT TO MAST ARM. REMOVE EXISTING STREET NAME SIGN. INSTALL CONTRACTOR SUPPLIED VEHICLE DETECTION CAMERA EQUIPMENT TO MAST ARM. LOCATION SHALL BE FIELD LOCATED BY THE ENGINEER PRIOR TO INSTALLATION. TERMINATE WIRING PER SHEET NO. TS-2.
- 3. SIGNAL STANDARD NO. 3  
INSTALL TWO CITY SUPPLIED AUDIBLE PEDESTRIAN PUSHBUTTON STATIONS WITH R10-3B INDICATION ON SIGNAL POLE. INSTALL CITY SUPPLIED INTERNALLY ILLUMINATED STREET NAME SIGN EQUIPMENT TO MAST ARM. REMOVE EXISTING STREET NAME SIGN. INSTALL CONTRACTOR SUPPLIED VEHICLE DETECTION CAMERA EQUIPMENT TO MAST ARM. LOCATION SHALL BE FIELD LOCATED BY THE ENGINEER PRIOR TO INSTALLATION. TERMINATE WIRING PER SHEET NO. TS-2.
- 4. SIGNAL STANDARD NO. 4  
INSTALL TWO CITY SUPPLIED AUDIBLE PEDESTRIAN PUSHBUTTON STATIONS WITH R10-3B INDICATION ON SIGNAL POLE. INSTALL CITY SUPPLIED INTERNALLY ILLUMINATED STREET NAME SIGN EQUIPMENT TO MAST ARM. REMOVE EXISTING STREET NAME SIGN. INSTALL CONTRACTOR SUPPLIED VEHICLE DETECTION CAMERA EQUIPMENT TO MAST ARM. LOCATION SHALL BE FIELD LOCATED BY THE ENGINEER PRIOR TO INSTALLATION. TERMINATE WIRING PER SHEET NO. TS-2.
- 5. REMOVE EXISTING 3 SECTION SIGNAL HEAD. INSTALL NEW 4 SECTION SIGNAL HEAD. USE MOUNT TYPE M PER WSDOT STANDARD PLAN J-75.20-01.
- 6. REMOVE EXISTING SIGNAL CONTROLLER CABINET. INSTALL NEW CITY SUPPLIED TYPE 333SD SIGNAL CONTROLLER CABINET. TERMINATE WIRING. SEE SHEET NO. TS-2.
- 7. TERMINATE EXISTING 6PCC INTERCONNECT CABLE IN SIGNAL CONTROLLER CABINET. SEE SHEET NO. TS-2.

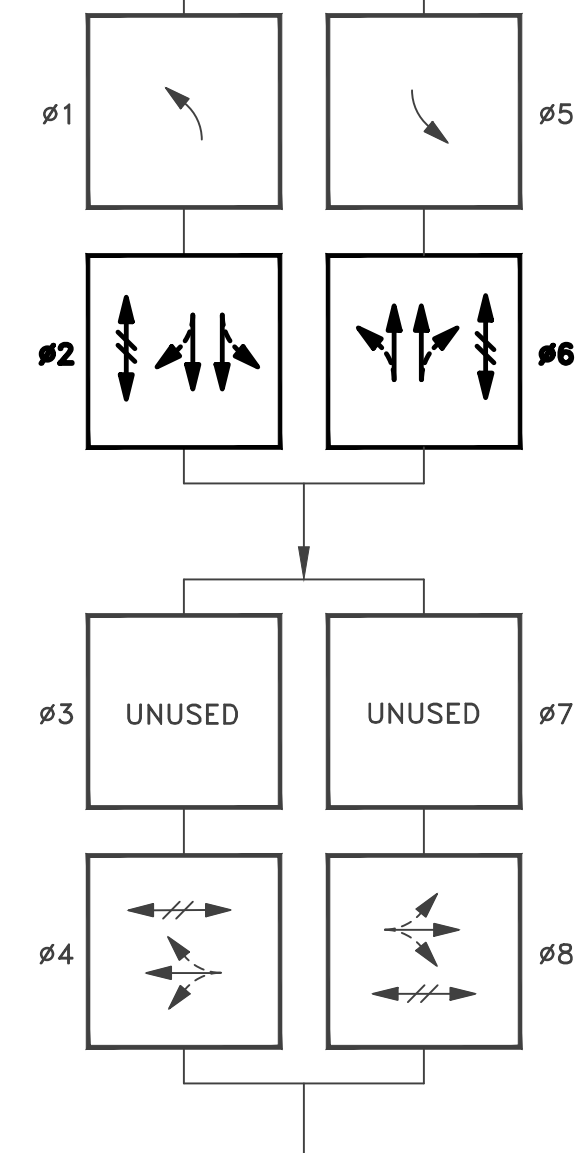
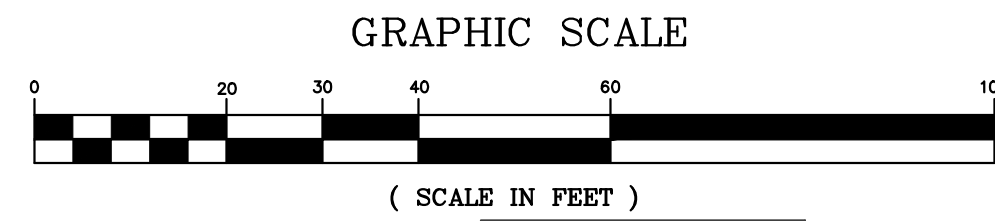

PEDESTRIAN MOVEMENT  
 PROTECTED VEHICLE MOVEMENT  
 PERMISSIVE VEHICLE MOVEMENT

**PROPOSED SIGNAL PHASING DIAGRAM**

**SIGNAL FACE SCHEDULE**

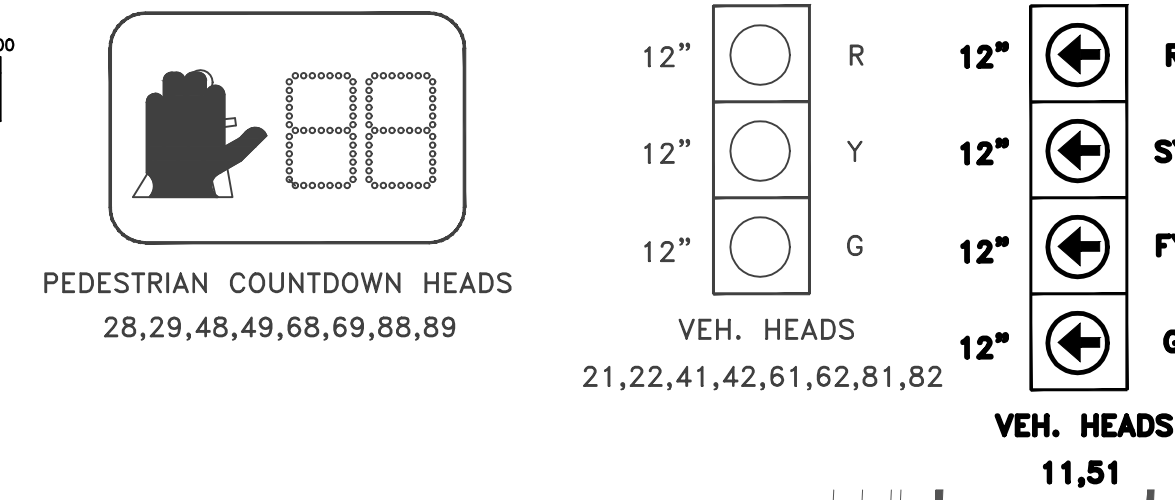

**NOTES:**

- 1. ALL VEHICLE SIGNAL HEADS SHALL BE BLACK LED HEADS WITH 12" FACES, BLACK FLAT ALUMINUM BACK PLATES AND BLACK ALUMINUM TUNNEL VISORS.
- 2. ALL VEHICLE SIGNAL HEADS SHALL USE MOUNTING TYPE M OR AS NOTED ON PLAN.
- 3. ALL SIGNAL HEADS AND TENONS SHALL BE SEPARATELY WIRED BETWEEN THE SIGNAL HEAD AND THE TERMINAL CABINET.
- 4. ALL PEDESTRIAN SIGNAL HEADS SHALL BE LED INTERNATIONAL SYMBOL TYPE.
- 5. ALL PEDESTRIAN SIGNAL HEADS SHALL BE BLACK, USING MOUNTING TYPE E SIGNAL STANDARD.

CIRCUIT	PHASE
A	2 & 5
B	4
C	1 & 6
D	8

**PREEMPTION SCHEDULE**

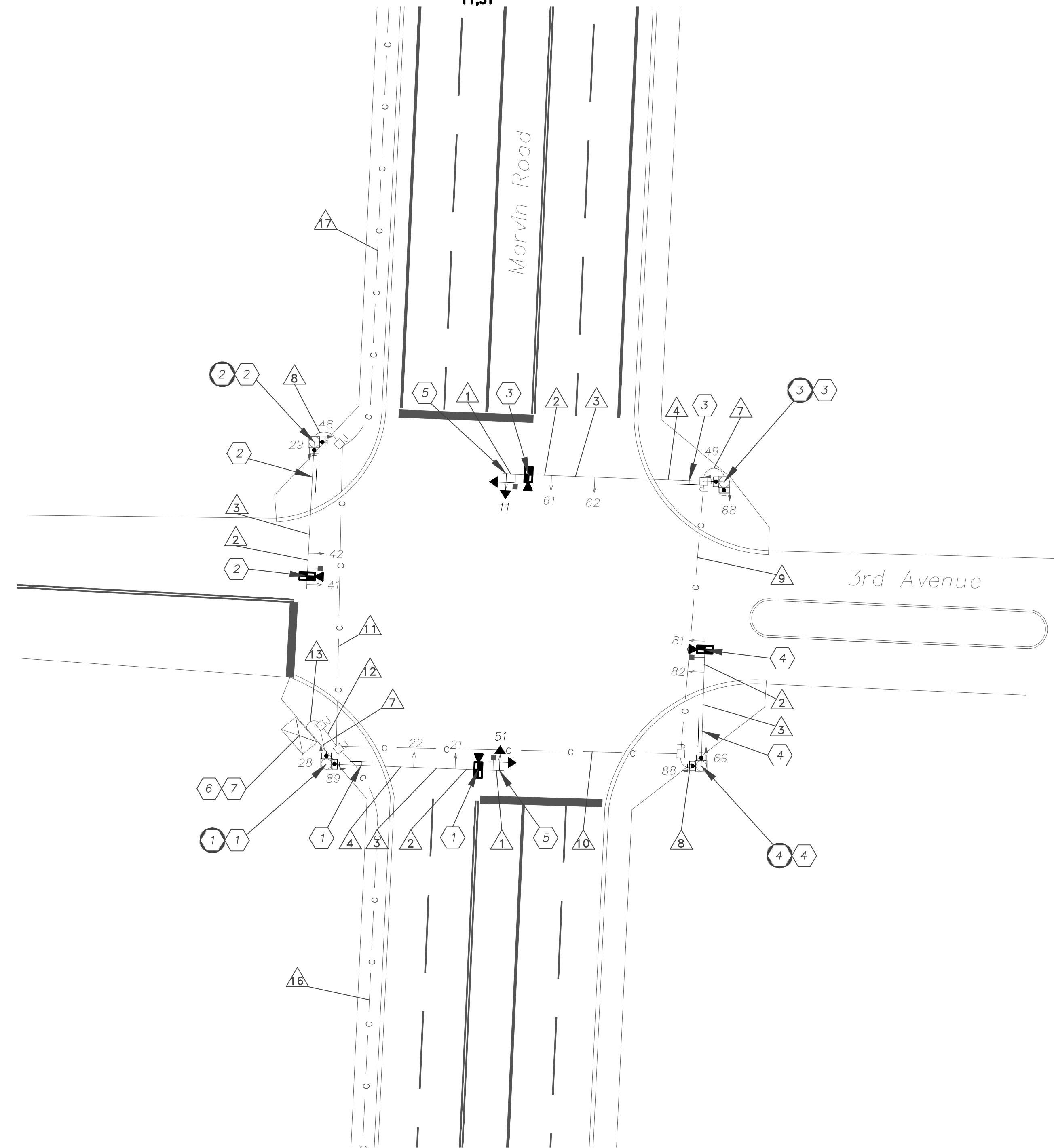

**WIRING SCHEDULE - MODIFICATIONS SHOWN**

PURPOSE	WIRE SPEC. & TYPE	CIRCUIT	RUN NUMBER																					
			1	2	3	4	5	6	7	8	9	10	11	12	13	14	15	16	17	18	19	20	21	22
SIGNAL HEADS	IMSA 20-1-1984 5 CONDUCTOR	PHASE 1	1	1	1	1			1		1	1		1	1									
		PHASE 5	1	1	1	1			1		1	1		1	1									
		SUBTOTAL	2	2	2	2			2		2	2		2	2									
VIDEO DETECTION CABLE	FLIR 3 CONDUCTOR	PHASE 2&5			1	1	1			1														
		PHASE 4			1	1	1			1		1	1		1	1								
		PHASE 6&1			1	1	1			1		1	1		1	1								
		PHASE 8			1	1	1			1		1	1		1	1								
		SUBTOTAL	4	4	2			2		2	1	2	1	3	4									
POWER	#8 BARE #12 USE	GROUND (IF NOT EX.)	1	1	1	1	1	1	1	1	1	1	1	1	1	1	1	1	1	1	1	1	1	
		STREET SIGNS 120V	2	2	1	2	1	3	4															
		SUBTOTAL	1	1	1	1		3	3	2	3	2	4	5										
INTERCONNECT	6 PAIR	SUBTOTAL									1	2	2											
		GRANDTOTAL	3	7	7	5		7	5	4	6	4	11	13							1	1		
		CONDUIT SIZE	ARM	M	M	M	M	M	M	M	M	M	M	M	M	M	M	M	M	M	M	M		
		SIZE	2"	1"	2"	2.5"	2"	3"	3.5"											2"	2"			

▲ TRIANGLE DENOTES RUN NUMBER (TYPICAL)

**CITY OF LACEY, WASHINGTON**  
 DEPARTMENT OF PUBLIC WORKS  
 420 COLLEGE STREET SE  
 LACEY, WA 98503-1238 (360) 491-5600

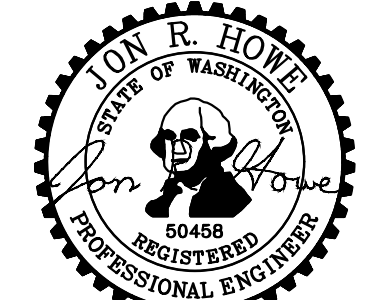

DESIGNED: JH  
 DRAFTED: JH  
 CHECKED: MAH  
 HORZ. SCALE: N/A  
 VERT. SCALE: N/A  
 TRAFFIC SIGNAL FINAL.DWG

**MARVIN ROAD ANNEXATION  
 SIGNAL IMPROVEMENTS  
 3RD AVENUE SIGNAL PLAN**

REVISION BLOCK		
NO.	DATE	DESCRIPTION

SHEET NO.	PAGE NO.
TS1	3
DWG NO.	OF
D-25-21	7

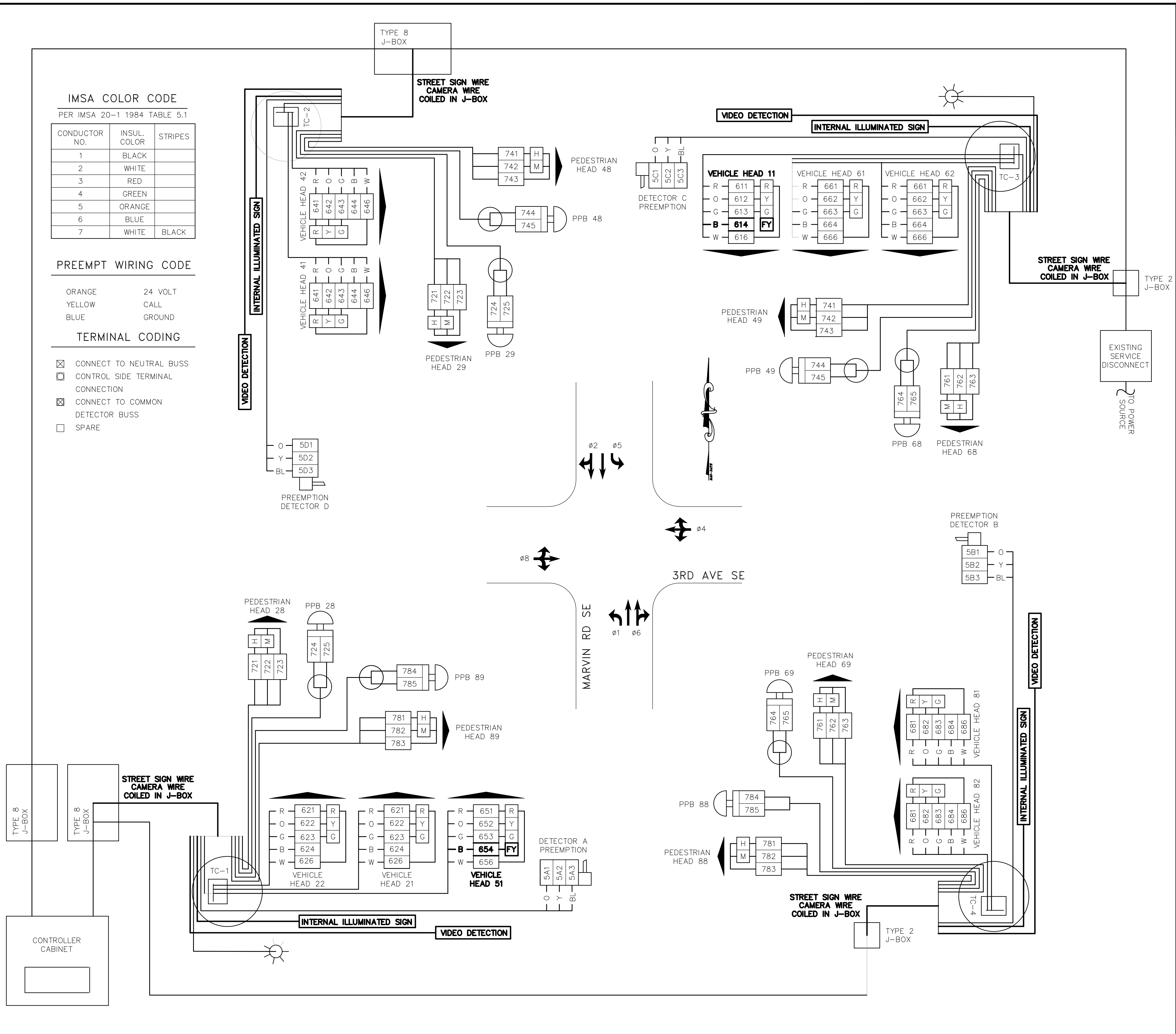
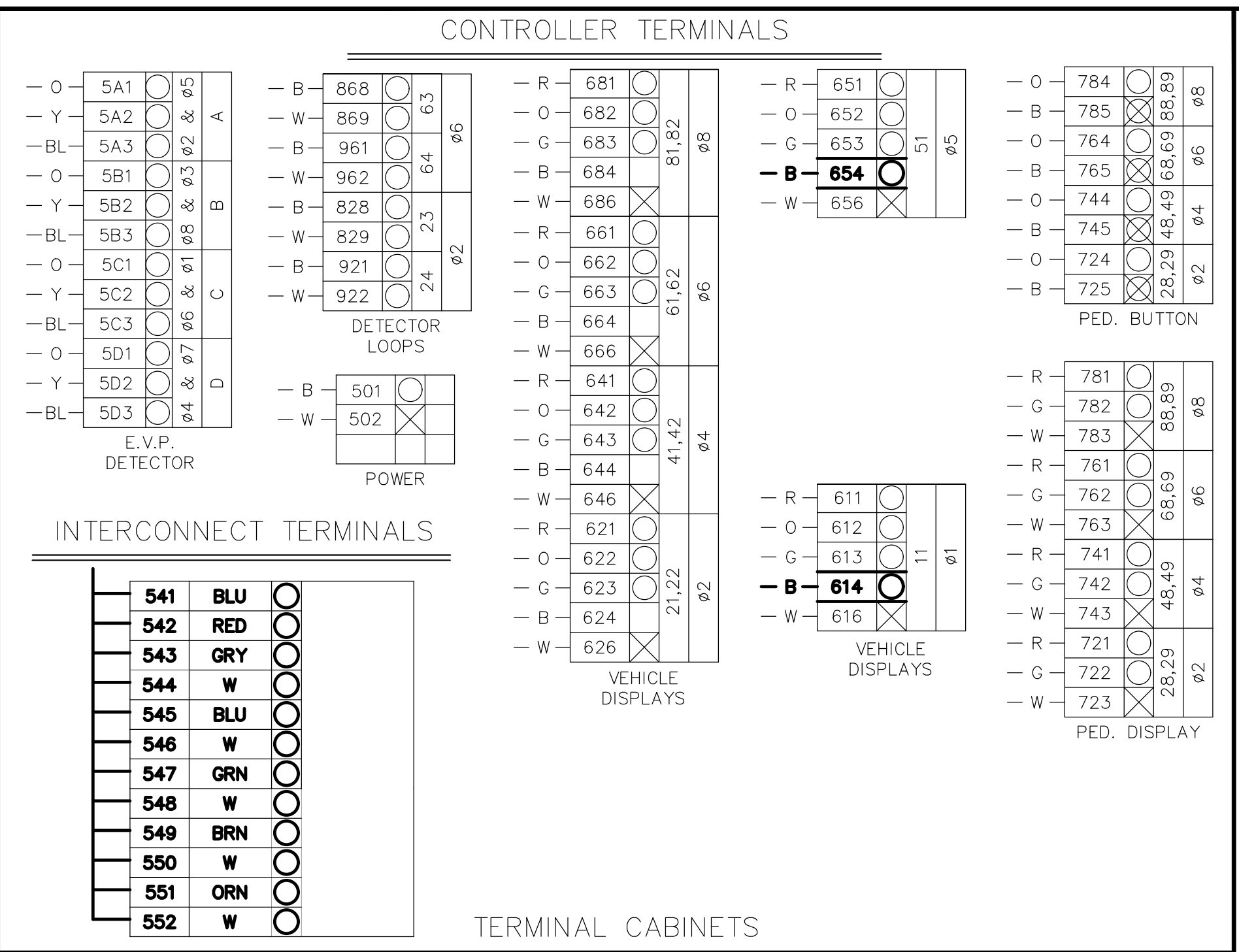

## MARVIN ROAD ANNEXATION SIGNAL IMPROVEMENTS 3RD AVENUE WIRING DIAGRAM

REVISION BLOCK		
NO.	DATE	DESCRIPTION

**CONSTRUCTION NOTES:**

1. SIGNAL STANDARD NO. 1  
INSTALL TWO CITY SUPPLIED AUDIBLE PEDESTRIAN PUSHBUTTON STATIONS WITH R10-3B INDICATION ON SIGNAL POLE. INSTALL CITY SUPPLIED INTERNALLY ILLUMINATED STREET NAME SIGN EQUIPMENT TO MAST ARM. REMOVE EXISTING STREET NAME SIGN. INSTALL CONTRACTOR SUPPLIED VEHICLE DETECTION CAMERA EQUIPMENT TO MAST ARM. LOCATION SHALL BE FIELD LOCATED BY THE ENGINEER PRIOR TO INSTALLATION. TERMINATE WIRING PER SHEET NO. TS-4.
2. SIGNAL STANDARD NO. 2  
INSTALL TWO CITY SUPPLIED AUDIBLE PEDESTRIAN PUSHBUTTON STATIONS WITH R10-3B INDICATION ON SIGNAL POLE. INSTALL CITY SUPPLIED INTERNALLY ILLUMINATED STREET NAME SIGN EQUIPMENT TO MAST ARM. REMOVE EXISTING STREET NAME SIGN. INSTALL CONTRACTOR SUPPLIED VEHICLE DETECTION CAMERA EQUIPMENT TO MAST ARM. LOCATION SHALL BE FIELD LOCATED BY THE ENGINEER PRIOR TO INSTALLATION. TERMINATE WIRING PER SHEET NO. TS-4.
3. SIGNAL STANDARD NO. 3  
INSTALL TWO CITY SUPPLIED AUDIBLE PEDESTRIAN PUSHBUTTON STATIONS WITH R10-3B INDICATION ON SIGNAL POLE. INSTALL CITY SUPPLIED INTERNALLY ILLUMINATED STREET NAME SIGN EQUIPMENT TO MAST ARM. REMOVE EXISTING STREET NAME SIGN. INSTALL CONTRACTOR SUPPLIED VEHICLE DETECTION CAMERA EQUIPMENT TO MAST ARM. LOCATION SHALL BE FIELD LOCATED BY THE ENGINEER PRIOR TO INSTALLATION. TERMINATE WIRING PER SHEET NO. TS-4.
4. SIGNAL STANDARD NO. 4  
INSTALL TWO CITY SUPPLIED AUDIBLE PEDESTRIAN PUSHBUTTON STATIONS WITH R10-3B INDICATION ON SIGNAL POLE. INSTALL CITY SUPPLIED INTERNALLY ILLUMINATED STREET NAME SIGN EQUIPMENT TO MAST ARM. REMOVE EXISTING STREET NAME SIGN. INSTALL CONTRACTOR SUPPLIED VEHICLE DETECTION CAMERA EQUIPMENT TO MAST ARM. LOCATION SHALL BE FIELD LOCATED BY THE ENGINEER PRIOR TO INSTALLATION. TERMINATE WIRING PER SHEET NO. TS-4.
5. REMOVE EXISTING SIGNAL CONTROLLER CABINET. INSTALL NEW CITY SUPPLIED TYPE 333SD SIGNAL CONTROLLER CABINET. TERMINATE WIRING. SEE SHEET NO. TS-4.
6. TERMINATE EXISTING 6PCC INTERCONNECT CABLE IN SIGNAL CONTROLLER CABINET. SEE SHEET NO. TS-4.
7. INSTALL ELECTRICAL CONNECTION TO EXISTING LACEY SERVICE CABINET. INSTALL 40 AMP BREAKER FOR TRAFFIC SIGNAL & 30 AMP BREAKER FOR INTERSECTION LIGHTING.
8. REMOVE AND DISCARD WSDOT SERVICE CABINET, CONDUIT, WIRING AND ASSOCIATED EQUIPMENT. REMOVE ELECTRICAL SERVICE CONNECTION PER PUGET SOUND ENERGY REQUIREMENTS.

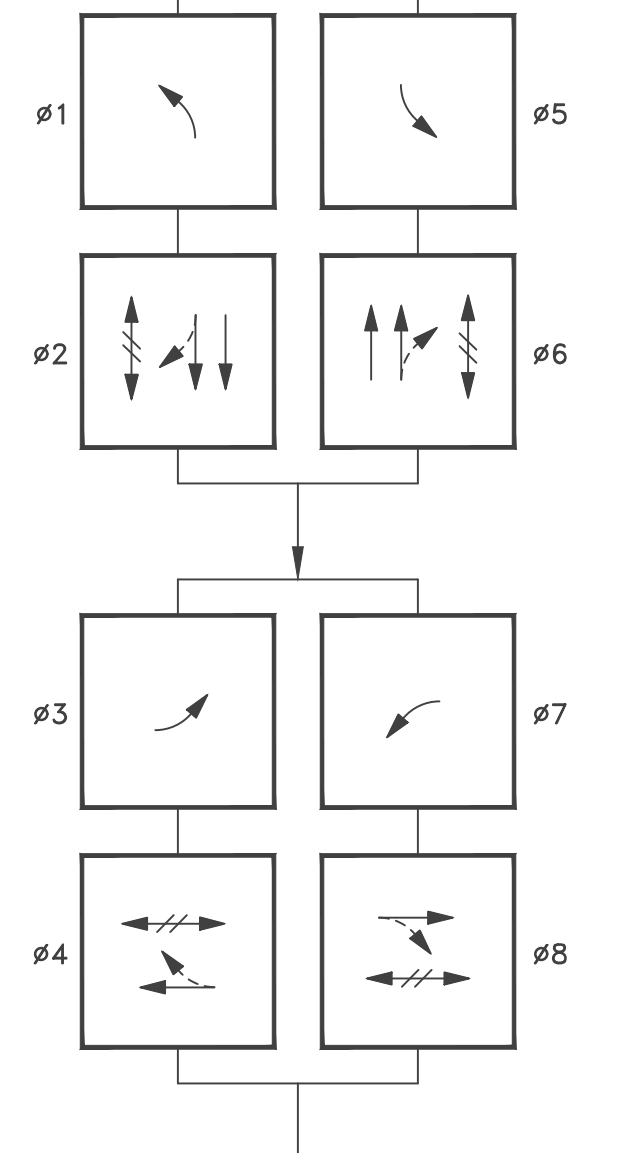
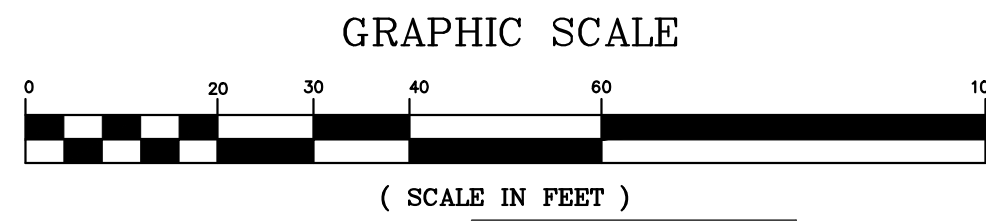

PEDESTRIAN MOVEMENT  
 PROTECTED VEHICLE MOVEMENT  
 PERMISSIVE VEHICLE MOVEMENT

**EXISTING SIGNAL PHASING DIAGRAM**

**EXISTING SIGNAL FACE SCHEDULE**

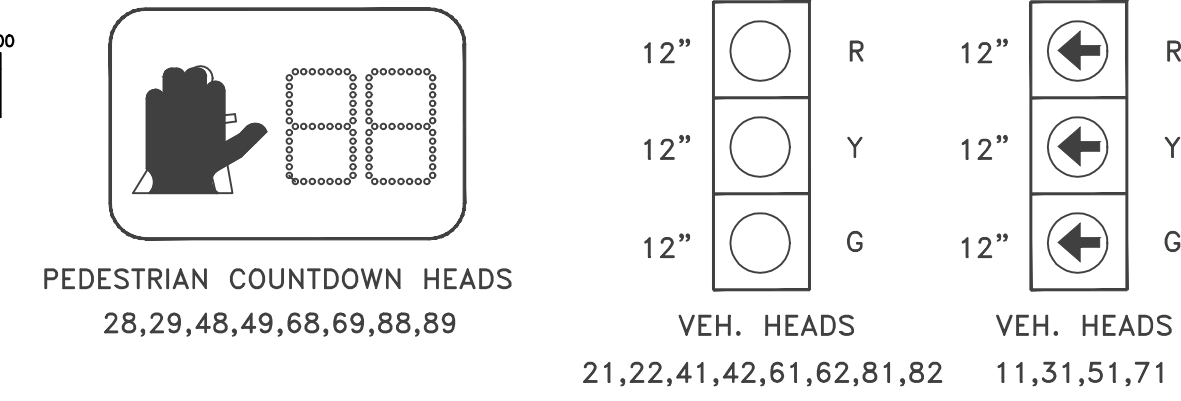

**NOTES:**

1. ALL VEHICLE SIGNAL HEADS SHALL BE BLACK LED HEADS WITH 12" FACES, BLACK FLAT ALUMINUM BACK PLATES AND BLACK ALUMINUM TUNNEL VISORS.
2. ALL VEHICLE SIGNAL HEADS SHALL USE MOUNTING TYPE M OR AS NOTED ON PLAN.
3. ALL PEDESTRIAN SIGNAL HEADS SHALL BE LED INTERNATIONAL SYMBOL TYPE.
4. ALL PEDESTRIAN SIGNAL HEADS SHALL BE BLACK, USING MOUNTING TYPE E SIGNAL STANDARD.

CIRCUIT	PHASE
A	2 & 5
B	4 & 7
C	1 & 6
D	3 & 8

**PREEMPTION SCHEDULE**

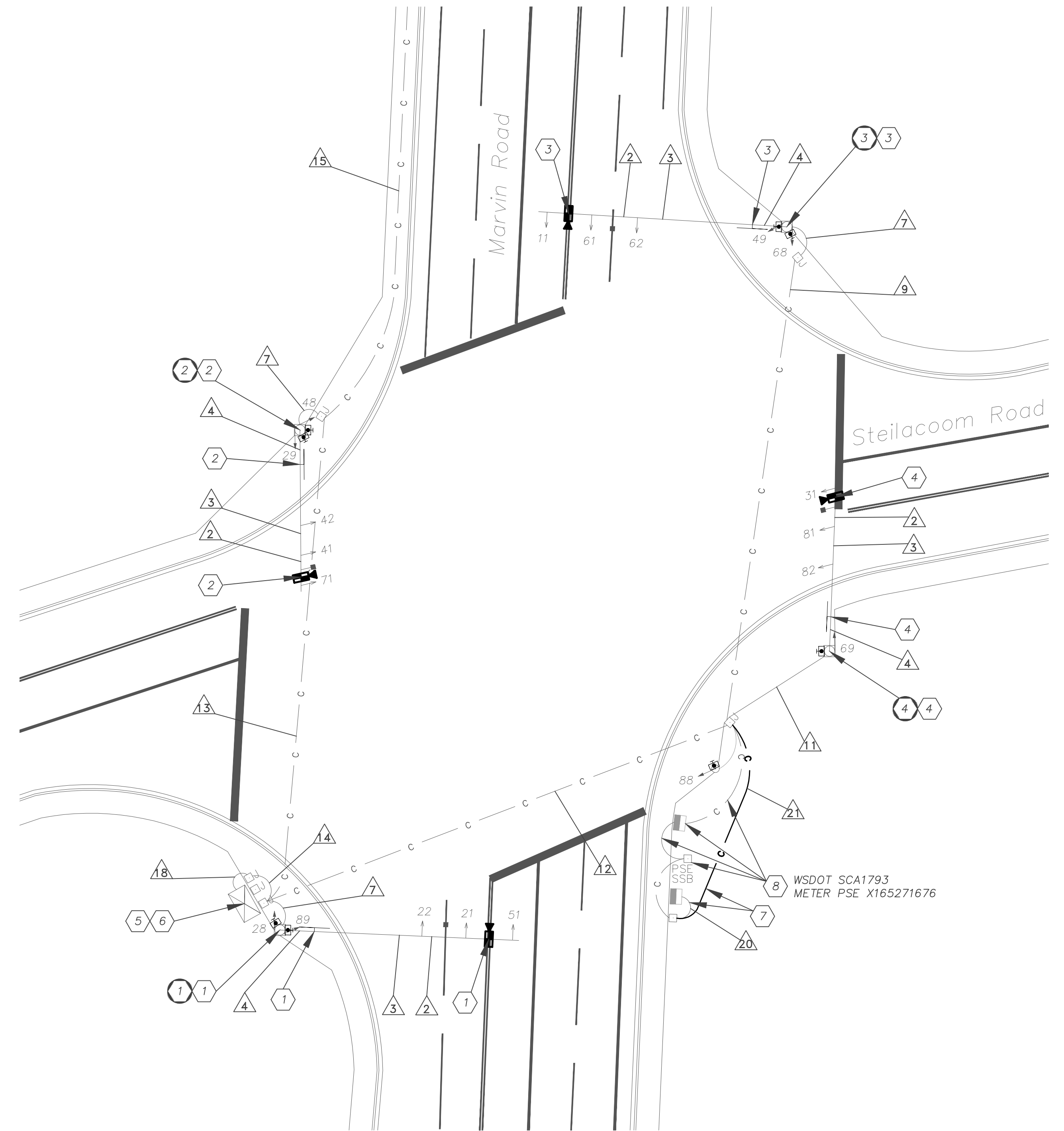

**WIRING SCHEDULE - MODIFICATIONS SHOWN**

PURPOSE	WIRE SPEC. & TYPE	CIRCUIT	RUN NUMBER																							
			1	2	3	4	5	6	7	8	9	10	11	12	13	14	15	16	17	18	19	20	21	22		
VIDEO DETECTION CABLE	FLIR 3 CONDUCTOR	PHASE 2&5	1	1	1																					
		PHASE 4&7	1	1	1																					
		PHASE 6&1	1	1	1																					
		PHASE 8&3	1	1	1																					
		SUBTOTAL	4	4	4																					
POWER	#8 BARE #12 USE #6 USE #8 USE	GROUND (IN NO EX.)				1																				
		STREET SIGNS 120V				4																				
		TRAFFIC SIGNAL																								
		INTERSECT. LIGHTING																								
		SUBTOTAL				5																				
INTERCONNECT	6 PAIR	SUBTOTAL																								
		GRANDTOTAL				9																				
		CONDUIT																								
		SIZE				ARM	ARM	ARM	ARM																	
		SIZE				2"	2"	2"	2"	1.5"	2.5"	2"	3.5"	2"												

▲ TRIANGLE DENOTES RUN NUMBER (TYPICAL)

**CITY OF LACEY, WASHINGTON**  
 DEPARTMENT OF PUBLIC WORKS  
 420 COLLEGE STREET SE  
 LACEY, WA 98503-1238 (360) 491-5600

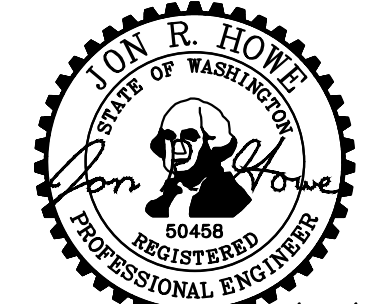

DESIGNED: JH  
 DRAFTED: JH  
 CHECKED: MAH  
 HORZ. SCALE: N/A  
 VERT. SCALE: N/A  
 TRAFFIC SIGNAL FINAL.DWG

**MARVIN ROAD ANNEXATION  
 SIGNAL IMPROVEMENTS  
 STEILACOOM ROAD SIGNAL PLAN**

REVISION BLOCK		
NO.	DATE	DESCRIPTION

SHEET NO.	PAGE NO.
TS3	5
DWG NO.	OF
D-25-21	7

CONTROLLER TERMINALS

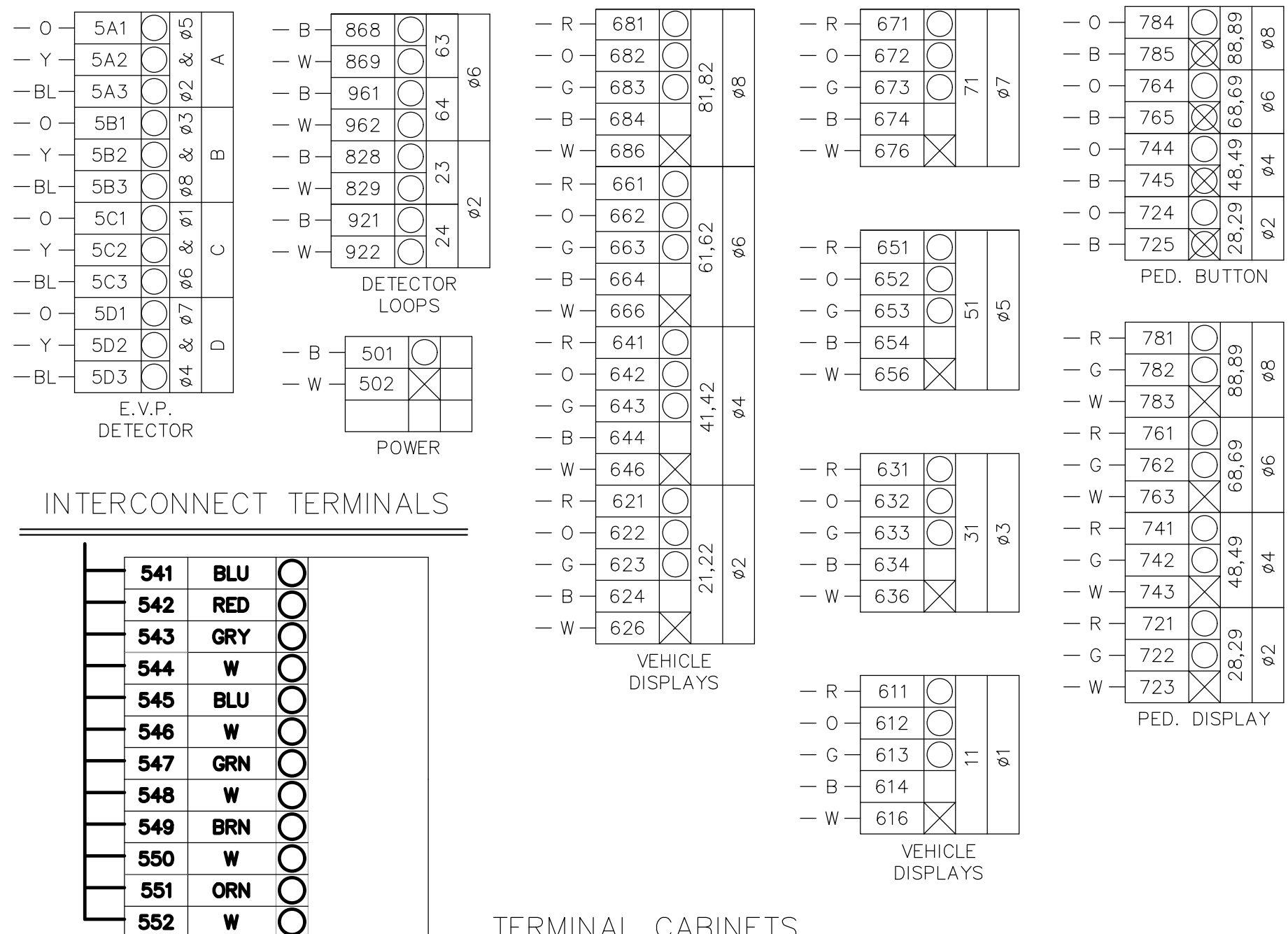

IMSA COLOR CODE

PER IMSA 20-1 1984 TABLE 5.1

CONDUCTOR NO.	INSUL. COLOR	STRIPES
1	BLACK	
2	WHITE	
3	RED	
4	GREEN	
5	ORANGE	
6	BLUE	
7	WHITE	BLACK

PREEMPT WIRING CODE

ORANGE	24 VOLT
YELLOW	CALL
BLUE	GROUND

TERMINAL CODING

- CONNECT TO NEUTRAL BUSS
- CONTROL SIDE TERMINAL CONNECTION
- CONNECT TO COMMON DETECTOR BUSS
- SPARE

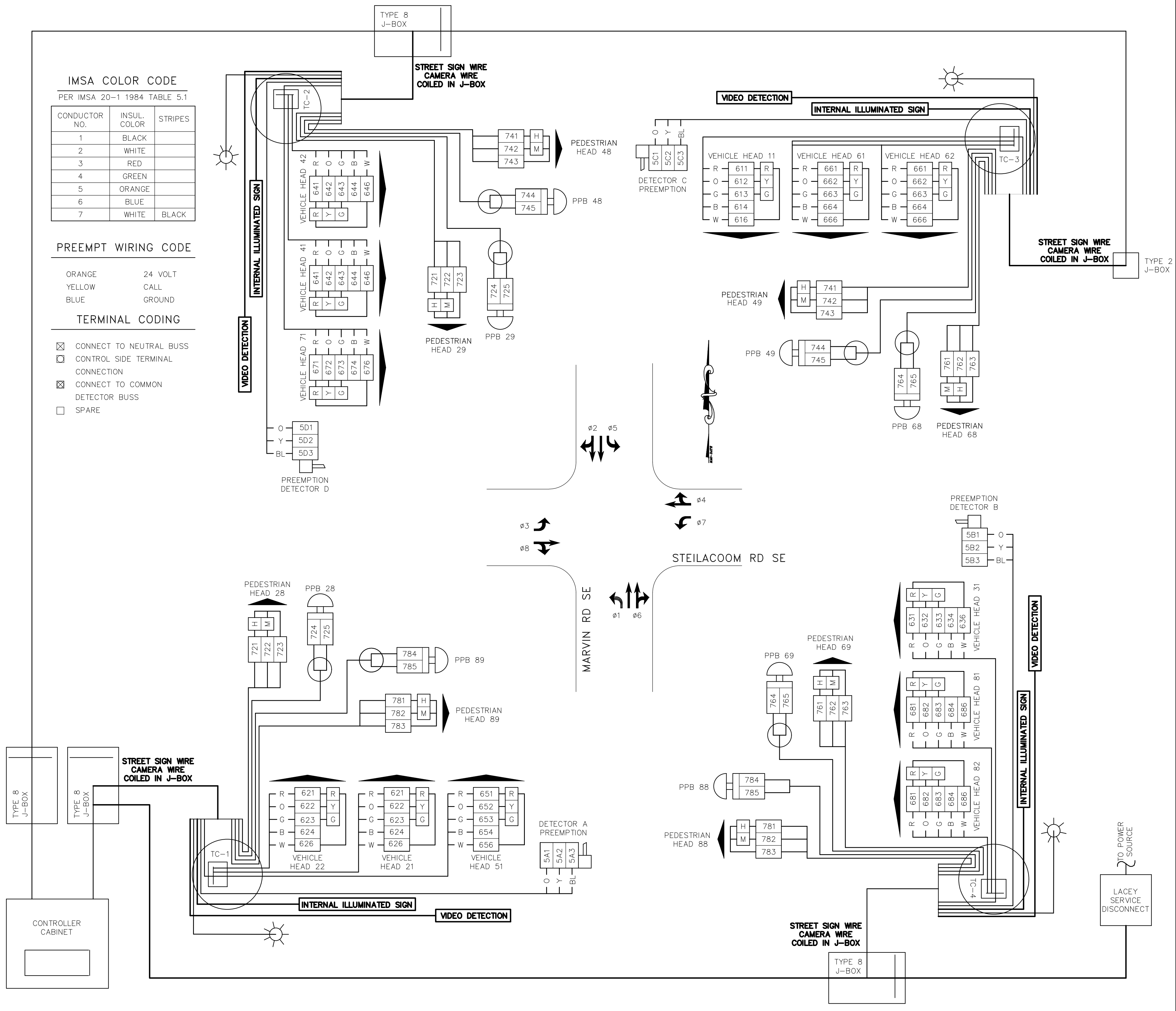

**MARVIN ROAD ANNEXATION  
 SIGNAL IMPROVEMENTS  
 STEILACOOM ROAD WIRING DIAGRAM**

REVISION BLOCK			SHEET NO.	PAGE NO.
NO.	DATE	DESCRIPTION	TS4	6
			DWG NO.	OF
			D-25-21	7

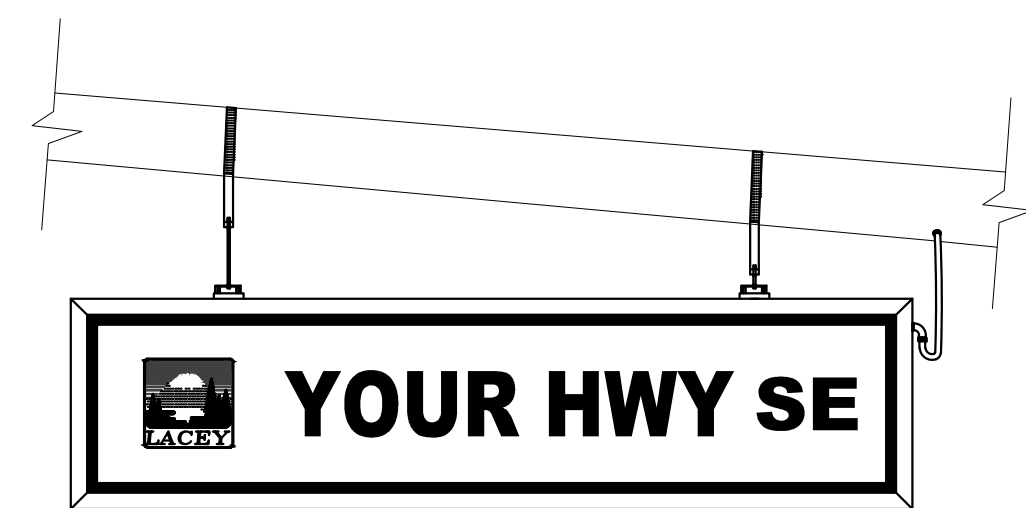
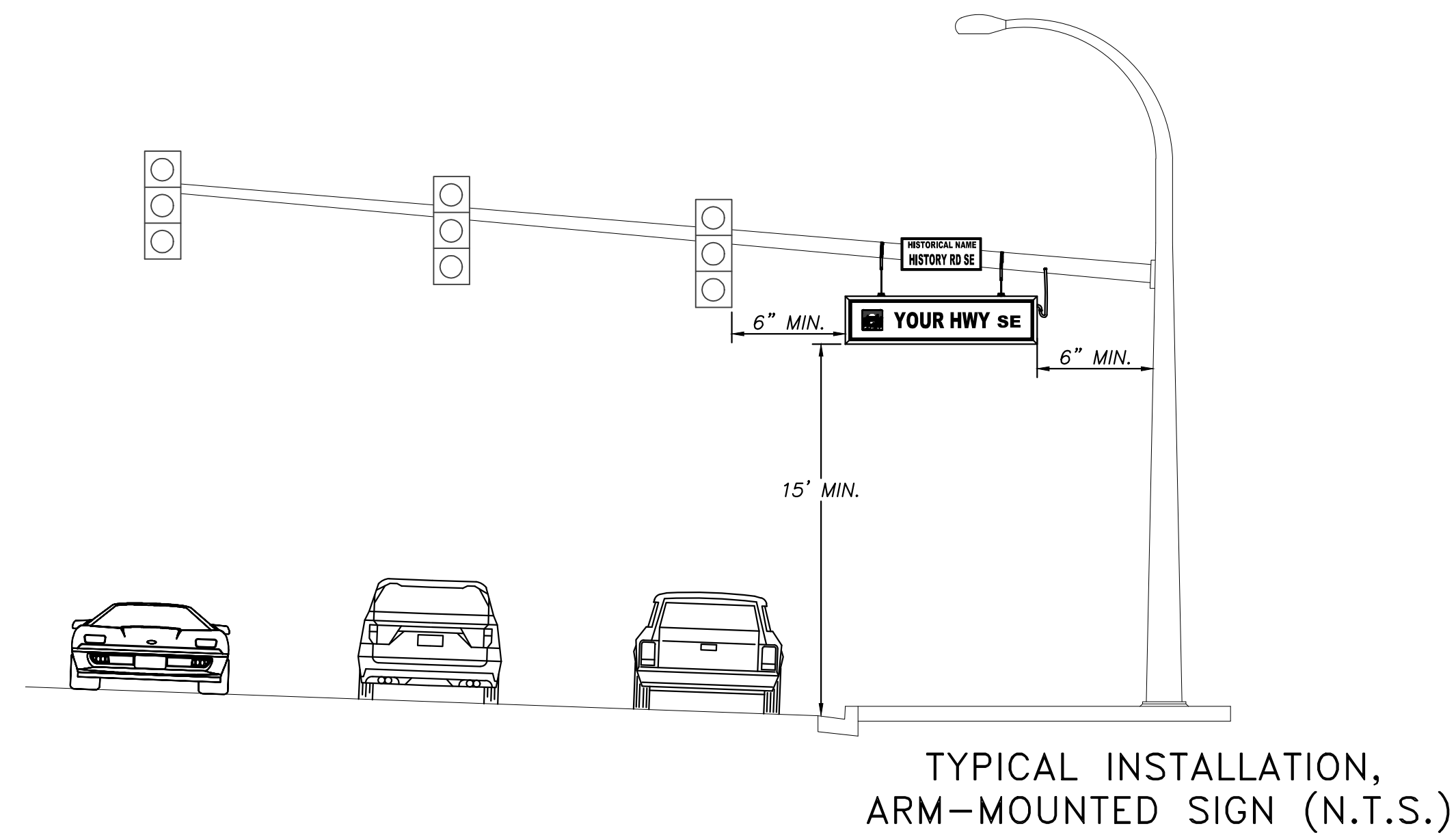

- NOTES:
1. ALIGN OUTSIDE EDGE OF SIGN WITH FLOWLINE OF GUTTER. IF NO CURB, ALIGN OUTSIDE EDGE OF SIGN WITH EDGE OF PAVEMENT.
  2. MINIMUM HORIZONTAL CLEARANCE TO ANY OTHER FIXTURE OR SIGN IS 6 INCHES.
  3. MINIMUM VERTICAL CLEARANCE TO ROAD IS 15 FEET.
  4. MINIMUM VERTICAL CLEARANCE TO MAST ARM IS 12 INCHES.
  5. MAXIMUM MOUNTING BRACKET LENGTH IS 32 INCHES.
  6. RELOCATE EXISTING HISTORICAL STREET NAME SIGN WITH NEW HARDWARE ON MAST ARM ABOVE INTERNALLY ILLUMINATED STREET NAME SIGN.
  7. ALL SIGNS SHALL BE INSTALLED LEVEL.

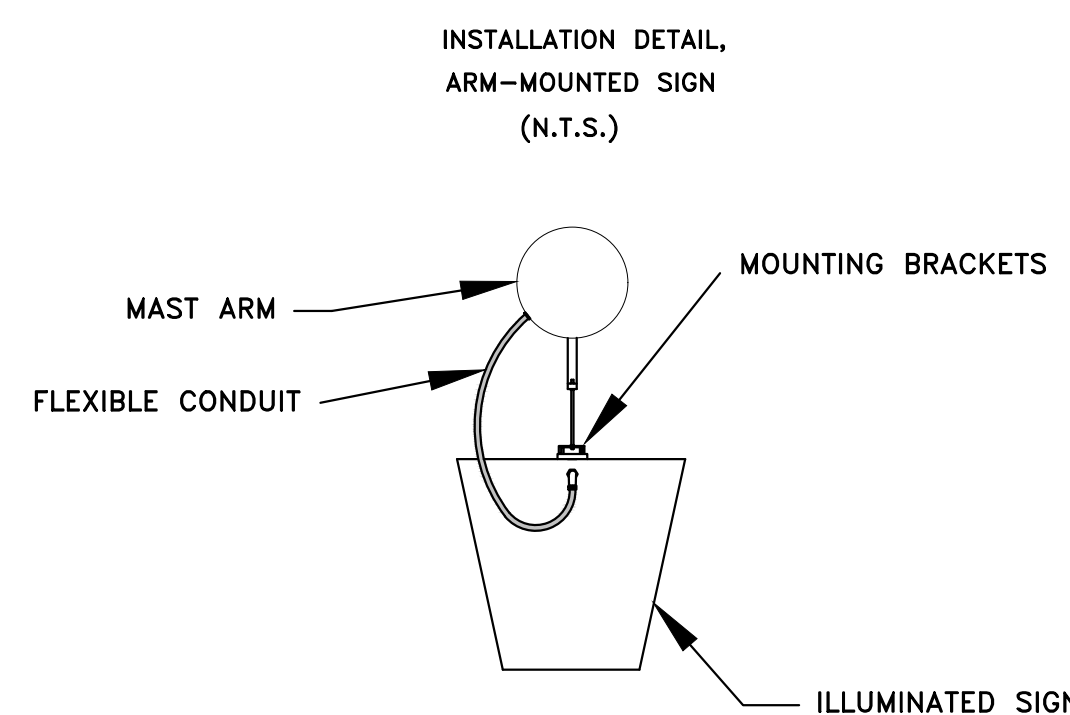

RIGHT SIDE VIEW  
INSTALLATION DETAIL  
ARM-MOUNTED SIGN  
(N.T.S.)

INTERNALLY ILLUMINATED  
STREET NAME SIGNS  
TYPICAL LOCATION  
INSTALLATION DETAIL

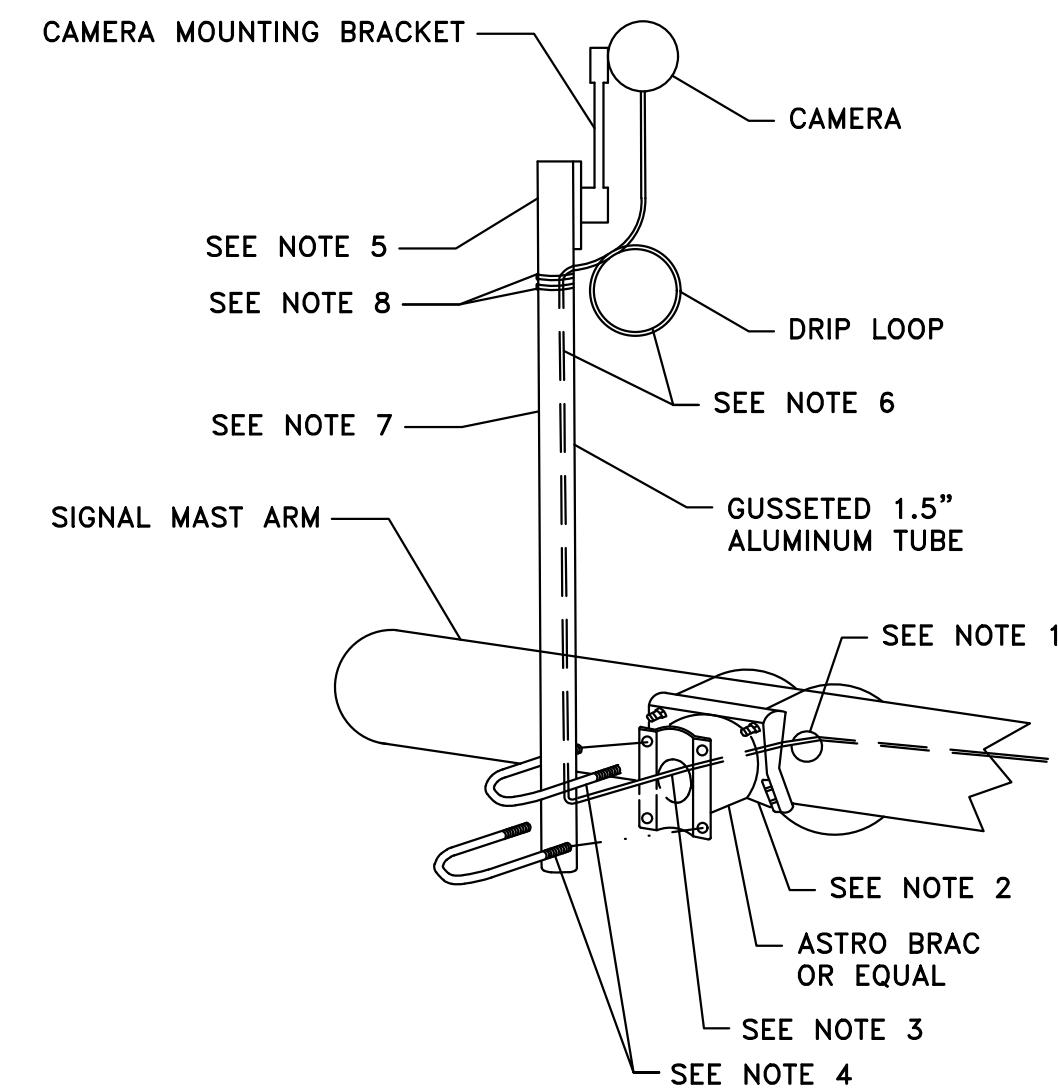

**NOTES**

1. THE CONTRACTOR SHALL DRILL A 1" HOLE IN THE BACK SIDE OF THE SIGNAL MAST ARM DEBURR, & PUT A RUBBER GROMMET IN HOLE. VERIFY MOUNTING LOCATION WITH ENGINEER PRIOR TO DRILLING.
2. THE ASTRO BRACKET SHALL BE INSTALLED OVER THE 1" HOLE.
3. VIDEO CABLE SHALL BE PULLED THROUGH THE SIGNAL MAST ARM THROUGH THE 1" HOLE AND THROUGH THE ASTRO BRACKET.
4. BOLT 1.5" GUSSETED TUBE TO ASTRO BRACKET.
5. ATTACH VIDEO CAMERA MOUNTING BRACKET TO THE TOP OF THE GUSSETED TUBE.
6. ROUTE VIDEO CABLE IN GUSSET TO THE INSIDE OF TUBE, UP THE TUBE EXITING TUBE AT TOP OF GUSSET AND CONNECT TO VIDEO JUNCTION BOX LEAVING A DRIP LOOP IN CABLE.
7. INSTALL VINYL INSERT IN GUSSET, LEAVING NO MORE THAN A 1" GAP AT THE TOP FOR CABLE TO EXIT THE TUBE.
8. INSTALL 2 BLACK WEATHER RATED WIRE TIES AROUND TUBE WHERE CABLES EXIT AT THE TOP OF THE VINYL INSERT.

**VEHICLE DETECTION  
CAMERA MOUNTING DETAIL**

VEHICLE DETECTION CAMERA  
INSTALLATION DETAIL

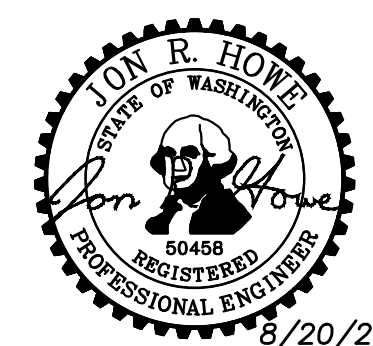

DESIGNED: JH  
DRAFTED: JH  
CHECKED: MAH  
HORZ. SCALE: N/A  
VERT. SCALE: N/A  
TRAFFIC SIGNAL FINAL.DWG

REVISION BLOCK		
NO.	DATE	DESCRIPTION

SHEET NO.	PAGE NO.
TS5	7
DWG NO.	OF
D-25-21	7